

Path Upgrade Torrens Linear Park



Jensen Planning + Design along with FMG Engineering were engaged by City of Charles Sturt to design and document a path upgrade along a section of Torrens Linear Park at Flinders Park.

The new path was designed to integrate with the existing pathway and needed to address issues and opportunities that the site presented such as:

- work to standard of 3m wide path + 0.5 for fence/ balustrade/ retaining edge
- where 3m width is not possible need to identify points/nodes for passing and provide suitable deck structure (as per previous stage).
- need to identify which trees need to be removed for provision of path
- stormwater issues
- need to maintain privacy into private rear yards

The final design was endorsed by Council and construction is currently underway.

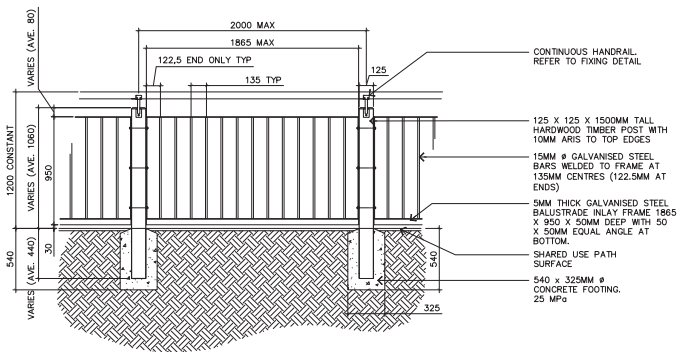

Location: Flinders Park
Adelaide, SA

Client: City of Charles Sturt

Date: 2008

In association with:
• FMG Engineering

